



FLEXITOL®

Systems for stepless tolerance compensation

BÖLLHOFF



Contents

	Page
Professional from A to Z	04
Why tolerance compensation?	05
Your benefits	05
FLEXITOL® technology	
– manual and automatic tolerance compensation systems	07
<i>Manual tolerance compensation system</i>	
General functional principle	10
FLEXITOL® K' in K'	11
<i>Automatic tolerance compensation system</i>	
General functional principle	14
FLEXITOL® metal	
– a selection of standard designs, technical data and processing tools	15
FLEXITOL® hybrid	
– a selection of standard designs and technical data	18
FLEXITOL® plastic	
– a selection of standard designs and technical data	19
<i>Our world of industries</i>	
Proven in many industries	22
Automotive	24
<i>Special solutions for the automotive industry</i>	
Fastening of rear lights	26
Fastening of roof rails	27

Böllhoff – Professional from A to Z

From A to Z we are the partner for your projects – from first concept to completion. Our dialogue with you is a thread throughout our working process. Thanks to smart innovation management and focused on realisation of your requirements, we develop tailor-made joint solutions right along your supply chain.

Get to know us personally and find out about the difference cooperation with us can make!

Why tolerance compensation?



In today's technology-oriented industry, time is becoming ever more important.

Wherever there is mass production, cycle times across the entire process chain must be kept short and thus economical. Optimised assembly processes are the key to efficient production.

The automotive industry is a very good example to illustrate the growing complexity of assembly processes.

Subcontractors provide pre-prepared modules and the automobile manufacturing plant then only has to carry out the final assembly. In "modular construction", standardised parts are assembled to complete systems (modular design principle).

In the respective development process, appropriate tolerances have to be defined to ease volume production. Manufacturers' and customers' high demands on reliable functions and first-run quality, such as small gap widths and require economical assembly solutions to compensate tolerances.

The automatic tolerance compensation system FLEXITOL® is a technically and economically optimised solution. Making tolerance compensation quick and easy.

Benefits

- Compensation of wide tolerances
- High performance reliability
- Access from one side only
- Easily integrates into a variety of applications
- High end product quality
- Fast and easy installation

Why tolerance compensation?

Complex adjustment processes during assembly are time-consuming and thus generate high costs. Small tolerances require precision and, in consequence, more expensive production methods. Reject rates and quality assurance costs also increase.

In practise:

- Joining tolerances required for quick assembly
- Individual tolerances stack up to become tolerance chains
- Component stress is avoided
- Allows for designs with redundant geometry
- Easy adjustment processes produce precise gap widths

FLEXITOL® – an efficient tolerance compensation system saving time and money.

The use of FLEXITOL® systems allows wider production tolerances so that production costs can be reduced.

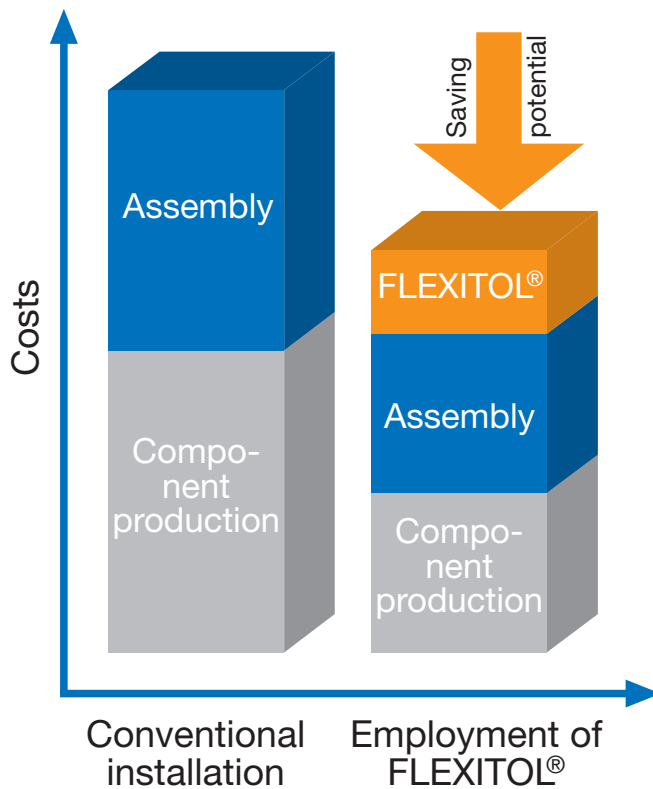

FLEXITOL® technology

Today we have manual and automatic tolerance compensation systems. Use of one or other depends on the field of application. When positioning a component in an assembly without any auxiliaries, then manual solutions are considered most appropriate. For a component spacing predefined by a preceding step, then we would rather recommend automatic solutions.

However, manual and automatic tolerance compensation systems may also be combined.

Let us compare the two systems:

Manual tolerance compensation

The tolerance compensation system is screwed into the receiving parts to a defined position. During screwing-in, the component tolerances can be compensated (Zero tolerance at delivery of the component). Further alignment is possible during installation. The adjusted position is maintained when the joint is loosened.

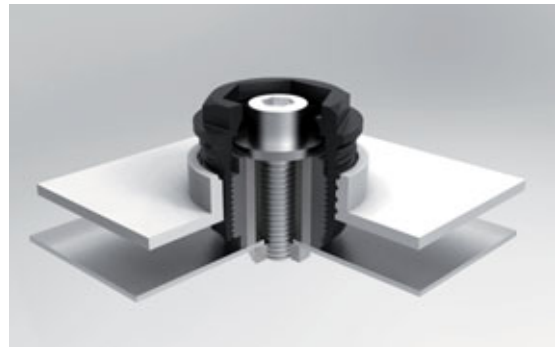

Manual

Automatic tolerance compensation

Two components are aligned toward each other / positioned. During screwing, the spacing between both components is automatically adjusted. The tolerance compensation system fixes the originally aligned position. If the joint is loosened, the system resumes the initial position.

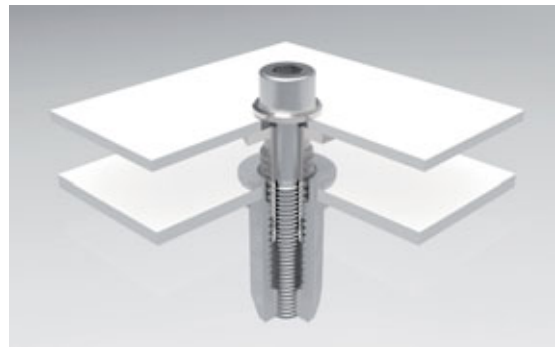

Automatic



- Receiving part:** Component in which the tolerance compensation system is installed.
- Mounting part:** Component screw fastened to the receiving part with tolerance compensation system.
- Basic element:** This system component is the basis of tolerance compensation. Usually, it is fixed and so provides a fastening thread.
- Adjustment element:** This element is screwed into the basic element and provides the required adjustment for tolerance compensation.
- Adjustment thread:** Joins basic element and adjustment element.
- Friction element:** Upon automatic tolerance compensation, it reacts to a defined torque from the screw to drive the adjustment element.

Manual tolerance compensation system



Contents

	Page
Professional from A to Z	04
Why tolerance compensation?	05
Your benefits	05
FLEXITOL® technology – manual and automatic tolerance compensation systems	07
<i>Manual tolerance compensation system</i>	
General functional principle	10
FLEXITOL® K' in K'	11
<i>Automatic tolerance compensation system</i>	
General functional principle	14
FLEXITOL® metal – a selection of standard designs, technical data and processing tools	15
FLEXITOL® hybrid – a selection of standard designs and technical data	18
FLEXITOL® plastic – a selection of standard designs and technical data	19
<i>Our world of industries</i>	
Proven in many industries	22
Automotive	24
<i>Special solutions for the automotive industry</i>	
Fastening of rear lights	26
Fastening of roof rails	27

Manual tolerance compensation system

General functional principle



The FLEXITOL® system (see figures) is supplied with a patented Böllhoff K' in K' thread.* This K' in K' thread is characterised by a unique thread profile. The different system variants are self-locking, self-tapping, self-forming, adjustable and tolerance compensating and are directly screwed into a plastic component. Component tolerances can be compensated by varying the screw-in depth.



After screwing-in, alignment to the second component is achieved.

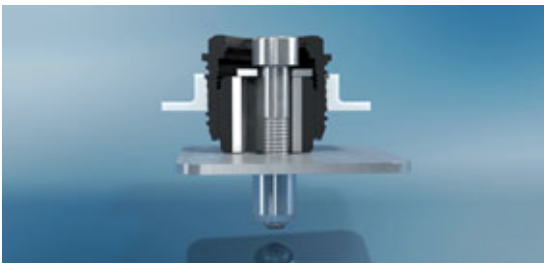

Prior to tightening the screw, radial tolerance compensation is also possible.



After the screw has been tightened with the torque, axial tolerance compensation is achieved.

Examples of manual tolerance compensation systems

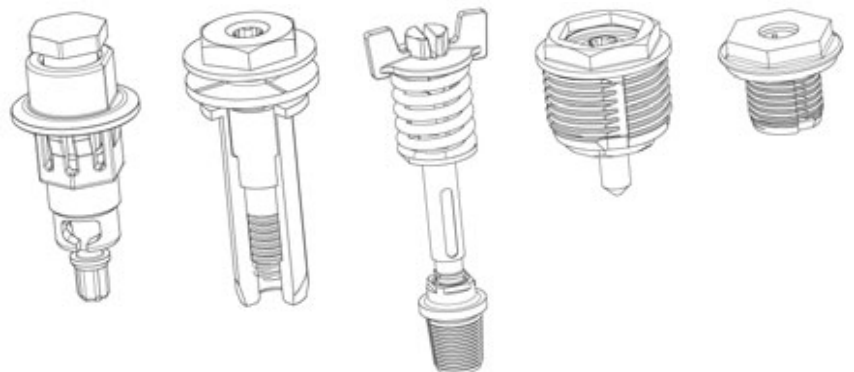

* The version with K' in K' thread is only one of many manual tolerance compensation systems.

FLEXITOL® K' in K'® example of the banjo screw



For "banjo screws", the function of the K' in K' thread is extremely important. The K' in K' thread creates its mounting thread into the existing plastic bore hole. Due to a resistance effect, the banjo screw can then only be screwed further in or out with a higher torque. We can offer different variants according to your requirements.

The examples below show banjo screws with:

- ① Through hole and internal drive
- ② Metal insert for M 6 thread with external and internal drive
- ③ Metal insert for M 6 thread and additional adapter for adjustment later
- ④ Bolt thread and seal
- ⑤ Bolt thread and locking device
- ⑥ Metal insert and through hole for three-dimensional tolerance compensation

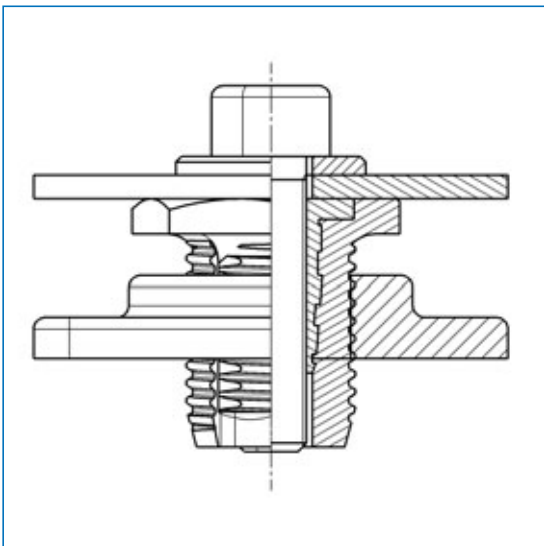

Automatic tolerance compensation system

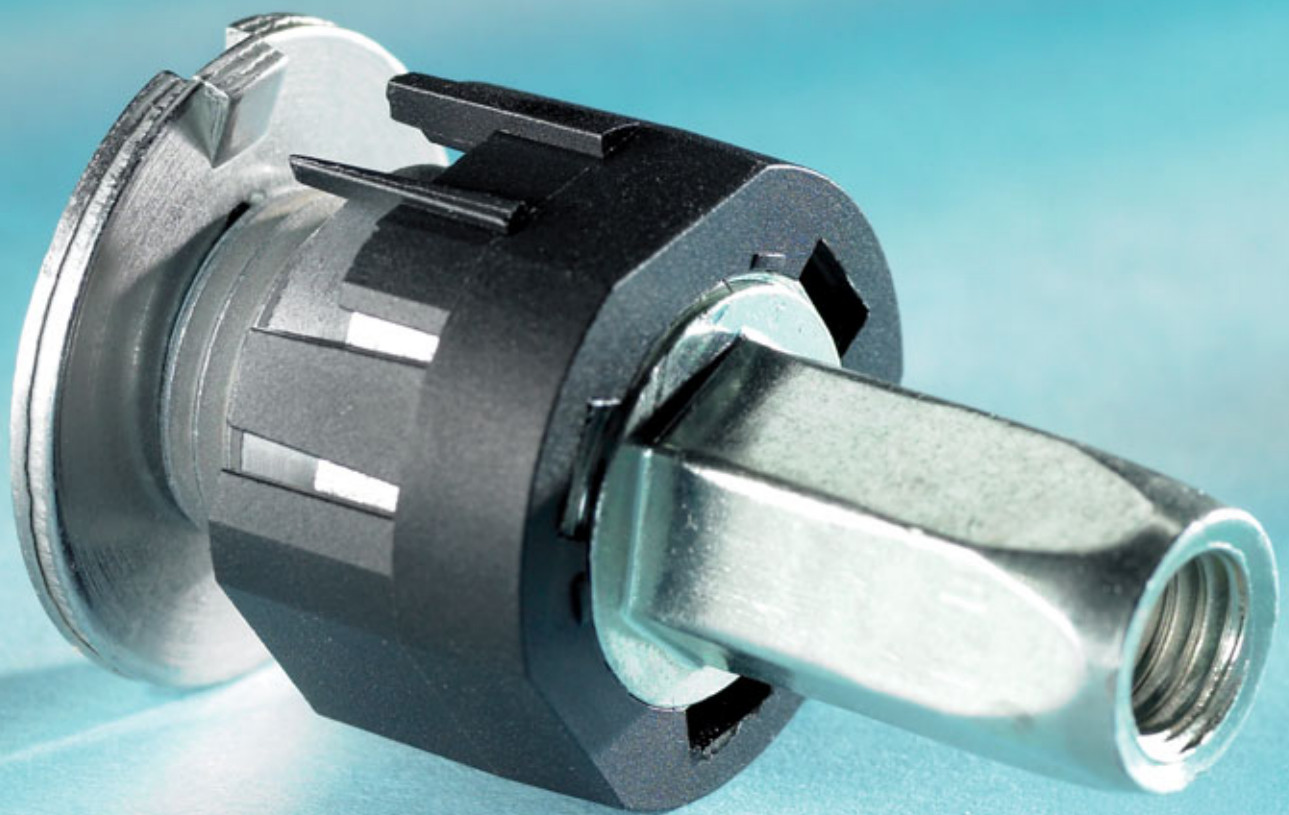

Contents

	Page
Professional from A to Z	04
Why tolerance compensation?	05
Your benefits	05
FLEXITOL® technology – manual and automatic tolerance compensation systems	07
<i>Manual tolerance compensation system</i>	
General functional principle	10
FLEXITOL® K' in K'	11
<i>Automatic tolerance compensation system</i>	
General functional principle	14
FLEXITOL® metal – a selection of standard designs, technical data and processing tools	15
FLEXITOL® hybrid – a selection of standard designs and technical data	18
FLEXITOL® plastic – a selection of standard designs and technical data	19
<i>Our world of industries</i>	
Proven in many industries	22
Automotive	24
<i>Special solutions for the automotive industry</i>	
Fastening of rear lights	26
Fastening of roof rails	27

Automatic tolerance compensation system

General functional principle



Installation and riveting of the basic element (RIVKLE® blind rivet nut) into the receiving part.

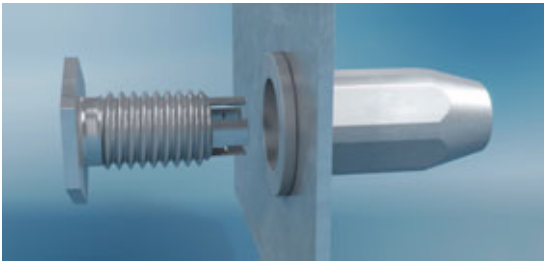

Screwing-in of the compensating element into the adjustment thread.



Alignment of the mounting part.



Upon screwing-in, the compensating element screws out and compensates eliminates the gap between the components. The aligned position is thus fixed.

Examples of automatic tolerance compensation systems



Automatic

FLEXITOL® metal

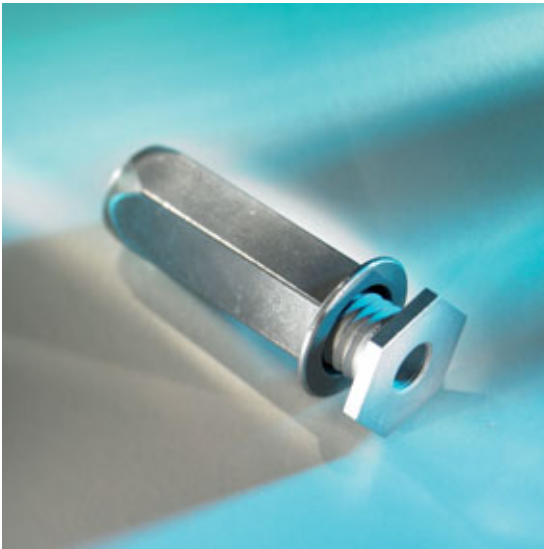

FLEXITOL® metal was the first tolerance compensation system developed by Böllhoff.

This two-component system is entirely made of metal and therefore highly wear-resistant. Due to the small space required for installation in the separation gap, this solution may easily be integrated and even retrofitted into an existing installation space.

Adjustment element

- Integrated friction
- Highly wear-resistant metal adjustment element

Fastening element

- Compact system
- Blind rivet nut available in different designs
- Easy installation using proven blind riveting technology

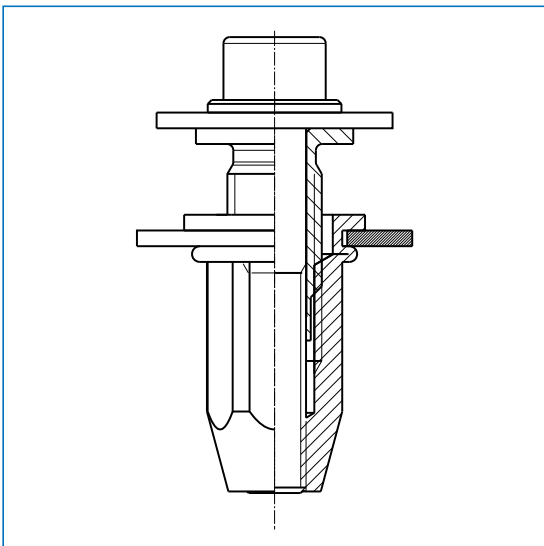

Standard program (excerpt) and technical data

Item code	0031 910 0011 + 2339 106 0843
Version	Blind rivet nut
Fastening thread	M 6
Inserted height	3.0 mm
Compensation distance	10 mm - e
Clamp area	2 – 3 mm (plastic)
Head diameter	A/F 17

Item code	0031 910 0011 + 2631 006 0001
Version	Blind rivet nut
Fastening thread	M 6
Inserted height	3.0 mm
Compensation distance	10 mm - e
Clamp area	0.5 – 3 mm (metal)
Head diameter	A/F 17

Item code	2641 008 0001 + 2631 008 0003
Version	Blind rivet nut
Abmessung	M 8
Inserted height	4.0 mm
Compensation distance	11 mm - e
Clamp area	0.5 – 3 mm
Head diameter	A/F 20

Item code	2721 008 0054 + 2631 008 0003
Version	Blind rivet nut
Abmessung	M 8
Inserted height	5.3 mm
Compensation distance	11 mm - e
Clamp area	0.5 – 3 mm
Head diameter	26 mm

e = material thickness receiving part

**Do you need a different size or variant?
Do not hesitate to contact us.**

Automatic tolerance compensation system



FLEXITOL® metal
Machine setting tool with hydraulic-pneumatic drive

Function:

Automatic touch on the mandrel to spin on the blind rivet nut. Force-controlled riveting is a hydraulic-pneumatic process.

When the button is pushed, setting starts and is completed after removal.

The stroke can be limited by means of an adjusting collar.

Use:

Medium and large production runs

Technical data:

Basic tool P2007 Left hand

- Item code: 2661 560 1002/10
- Capacity: up to 15 pieces/min.
- Weight: 2.7 kg
- Max. setting force: 21,000 N at 5.5 – 7 bar
- Range of use: FLEXITOL® M 6

Basic tool P3007 Left hand

- Item code: 2799 000 0094/10
- Capacity: up to 15 pieces/min.
- Weight: 3.4 kg
- Max. setting force: 40,000 N bei 5.5 – 7 bar
- Range of use: FLEXITOL® M 8

	FLEXITOL® M 6	FLEXITOL® M 8
Basic tool	2661 560 1002/10	2799 000 0094/10
Mandrel	2719 100 1005/10	2799 000 0095/10
Nosepiece	2719 100 1006/10	2361 591 2030/00
Screw-in tool for adjustment element	2799 060 1024/10	2799 080 1025/10
Complete tool	2761 551 0001/10	2761 551 0002/10

Automatic

FLEXITOL® metal
Screw-in tool for adjustment element



1. The tool consists of a bubble cap and a mandrel and can be inserted using a commercially available cordless screwdriver.

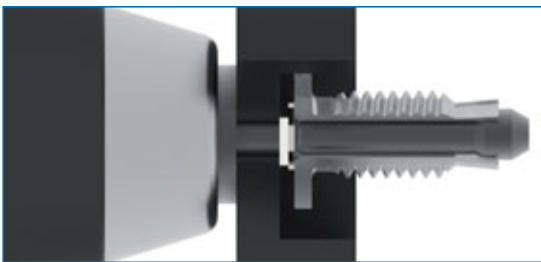

2. The adjustment element is plugged onto the tool. During this step, the friction elements are calibrated so that the friction torque range is reduced.

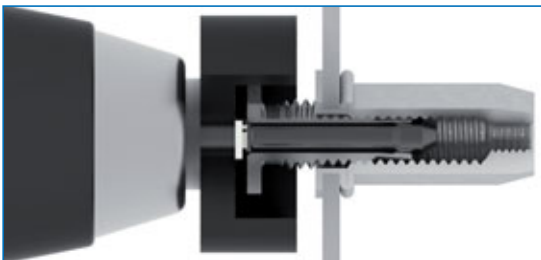

3. During screwing into the basic element, the adjustment element is driven by friction.

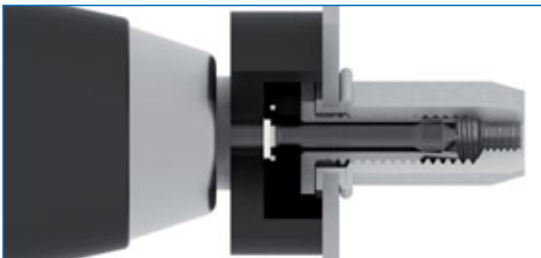

4. During screwing-in, the bubble cap touches the receiving part. The mandrel is withdrawn from the friction element.

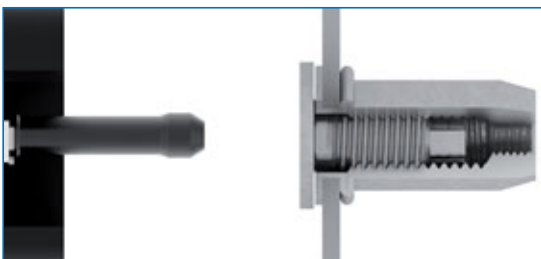

5. Thanks to the geometry, after screwing, the adjustment element is completely screwed in and not locked to the basic element.

Automatic tolerance compensation system



FLEXITOL® hybrid

The FLEXITOL® hybrid is a multi-component system primarily designed for use in large-scale production.

Due to its modular design, different inserted heights and tolerance compensation measures may easily be implemented.

To ensure force transmission is as high as possible, the force-transmitting components in this hybrid solution (plastics/metal) are made of metal. They are enclosed by a plastic nut cage.

Upon delivery, the system is pre-assembled and, arranged like that, can be installed into the receiving part with a setting tool.

The integrated blind rivet nut is already provided as fastening thread.

Alternative connections such as clip solutions are also available.

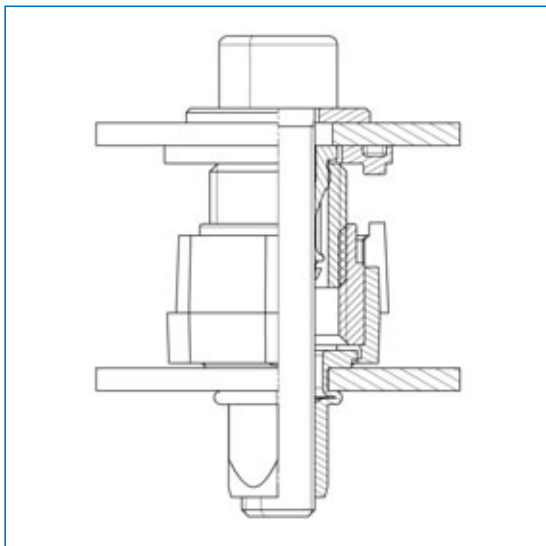

Blind rivet nut solution

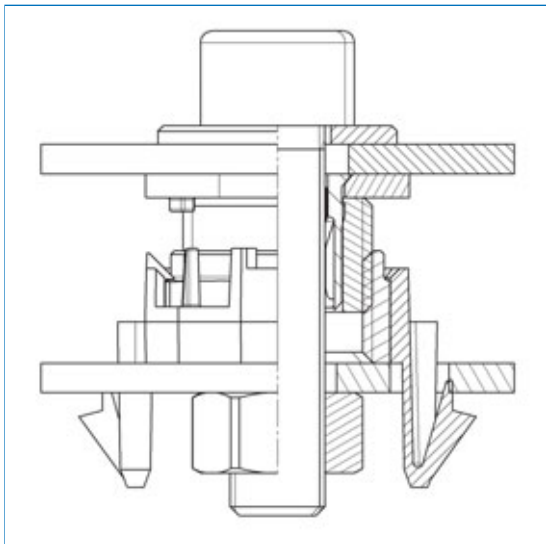

Clip version

Standard program (excerpt) and technical data

Item code	2707 008 0065
Version	Blind rivet nut
Fastening thread	M 8
Inserted height	18.0 mm
Compensation distance	10 mm
Clamp area	0.5 – 3 mm
Head diameter	25 mm

Item code	2707 008 0080
Version	Clips
Fastening thread	M 8
Inserted height	12.0 mm
Compensation distance	6.5 mm
Material thickness	2 – 3 mm
Head diameter	22 mm

Item code	2707 008 0078
Version	Clips
Size	M 8
Inserted height	16.0 mm
Compensation distance	8 mm
Material thickness	1 – 2.5 mm
Head diameter	33 mm

Do you need a different size or variant?

Do not hesitate to contact us.

Automatic

FLEXITOL® plastic



The FLEXITOL® plastic consists of a plastic adjustment element and a plastic fastening element and is supplied as a pre-assembled assembly.

This assembly should be screwed into the mounting hole in the plastic receiving part.

A bayonet variant offers another way to attach the basic element. The FLEXITOL® plastic is then inserted into a keyhole-shaped receiving opening and locked with a quarter turn. The subsequent installation is the same as for the self-tapping variant.

Depending on the version, a self-tapping metal screw or a metric screw can be used as fastening screw.

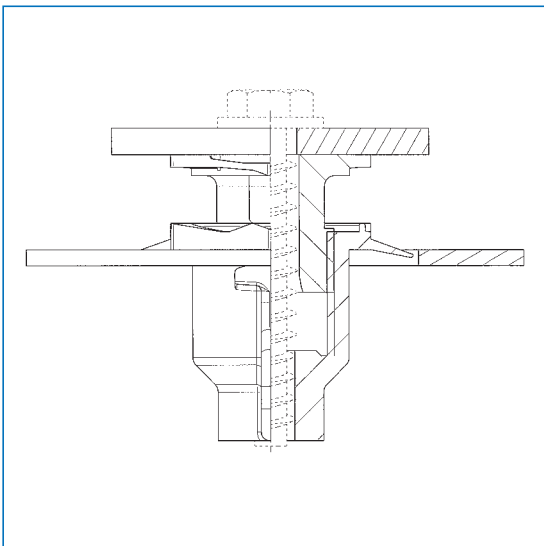

Bayonet-Variant

Standard program (excerpt) and technical data

Item code	2704 050 1001
Version	K' in K'
Fastening thread	self-tapping d = 5 mm
Inserted height	4.0 mm
Compensation distance	6 mm
Material thickness	min. 4 mm
Head diameter	A/F 19 mm

Item code	2705 050 1021
Version	Bayonet
Fastening thread	self-tapping d = 5 mm
Inserted height	4.0 mm
Compensation distance	6,0 mm
Material thickness	1,5 – 1,8 mm
Head diameter	A/F 19 mm

Item code	2705 060 0104
Version	Bayonet
Fastening thread	M 6
Inserted height	5.5 mm
Compensation distance	6.0 mm
Material thickness	3 mm
Head diameter	18 mm

Item code	2705 006 0057
Version	K' in K'
Size	M 6
Inserted height	5.5 mm
Compensation distance	6.0 mm
Material thickness	min. 5 mm
Head diameter	18 mm

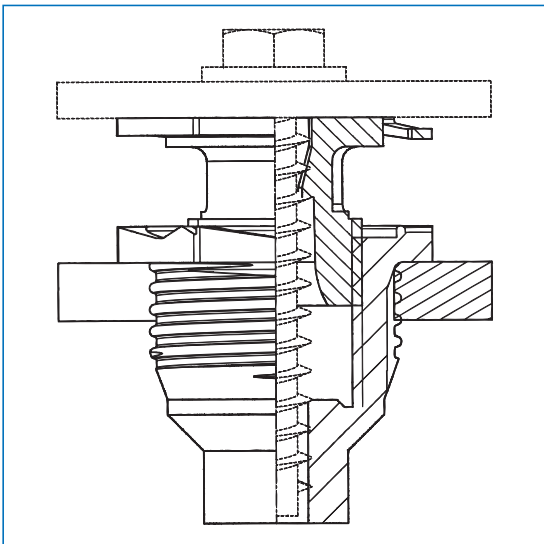

K' in K' Variant

**Do you need a different size or variant?
Do not hesitate to contact us.**

Our world of industries

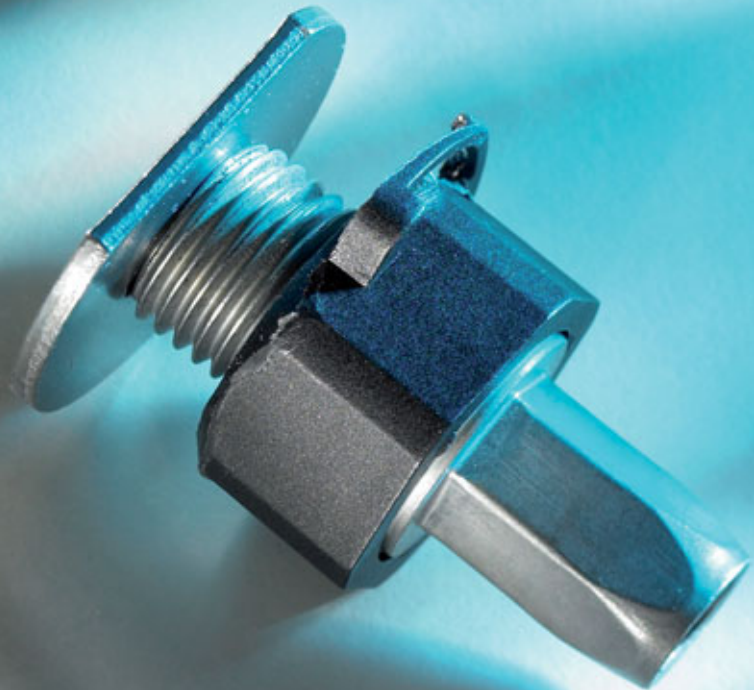

Contents

	Page
Professional from A to Z	04
Why tolerance compensation?	05
Your benefits	05
FLEXITOL® technology – manual and automatic tolerance compensation systems	07
<i>Manual tolerance compensation system</i>	
General functional principle	10
FLEXITOL® K' in K'	11
<i>Automatic tolerance compensation system</i>	
General functional principle	14
FLEXITOL® metal – a selection of standard designs, technical data and processing tools	15
FLEXITOL® hybrid – a selection of standard designs and technical data	18
FLEXITOL® plastic – a selection of standard designs and technical data	19
<i>Our world of industries</i>	
Proven in many industries	22
Automotive	24
<i>Special solutions for the automotive industry</i>	
Fastening of rear lights	26
Fastening of roof rails	27

Proven in many industries

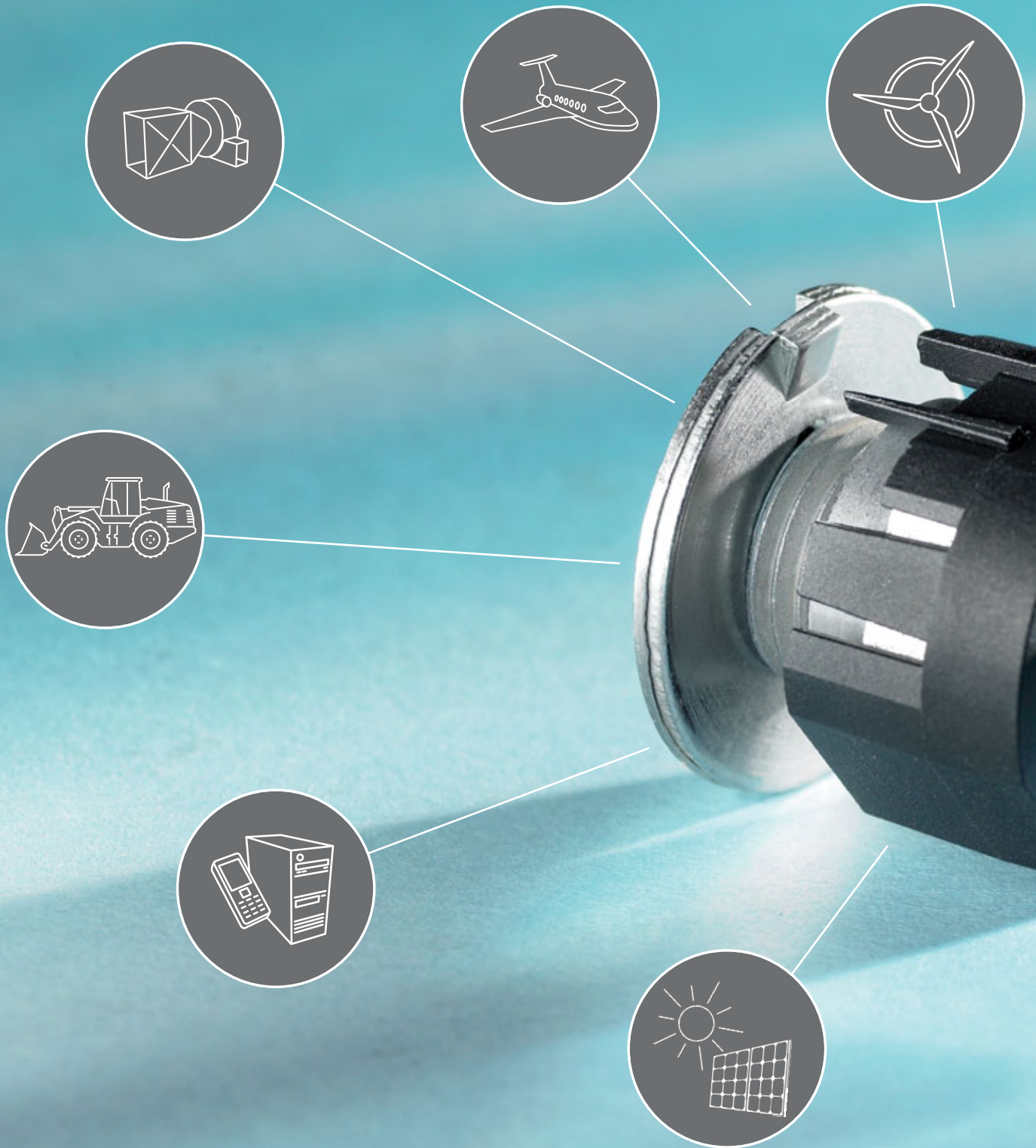

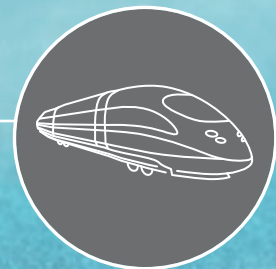
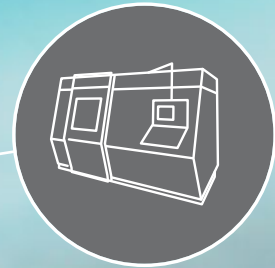
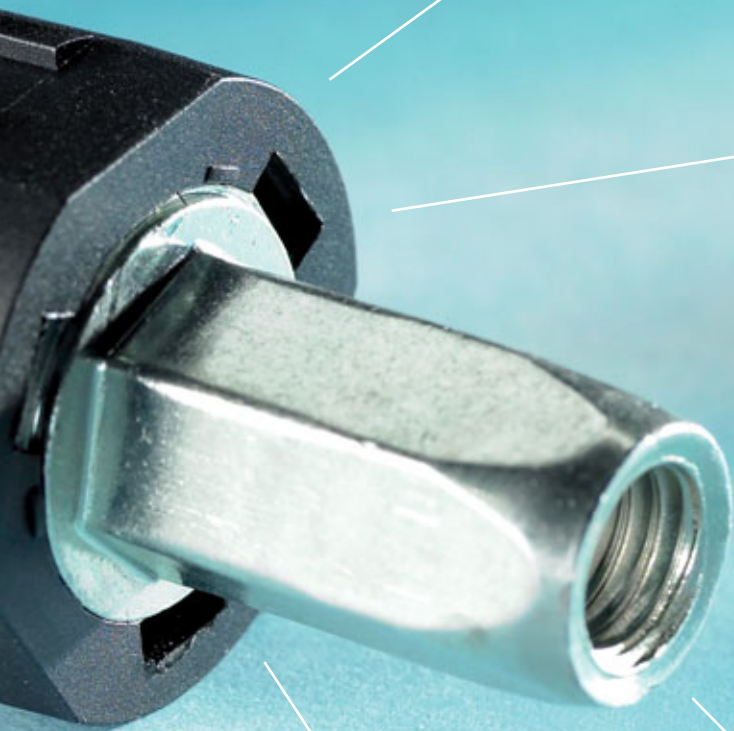

Fields of application – automotive

- Front-end-module fastenings (headlight installation)
- Flush installation of body components with controlled gap widths (between wing and door)
- Flush installation of fenders with alignment to adjacent body components
- Stress-free installation of seat rails with four-point mounting
- Door frames (integral members)
- Tension-free and correctly positioned installation of the dashboard

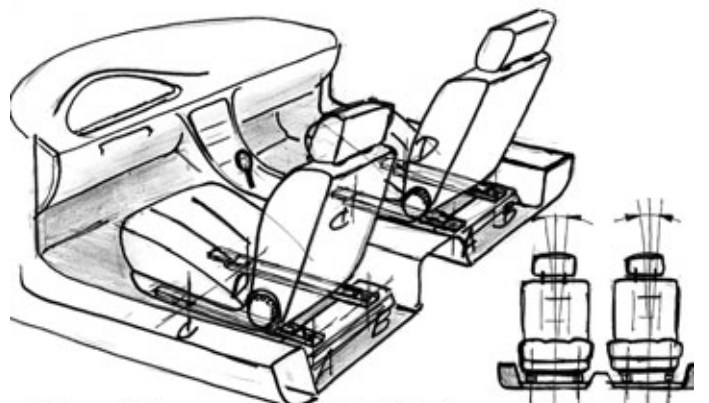
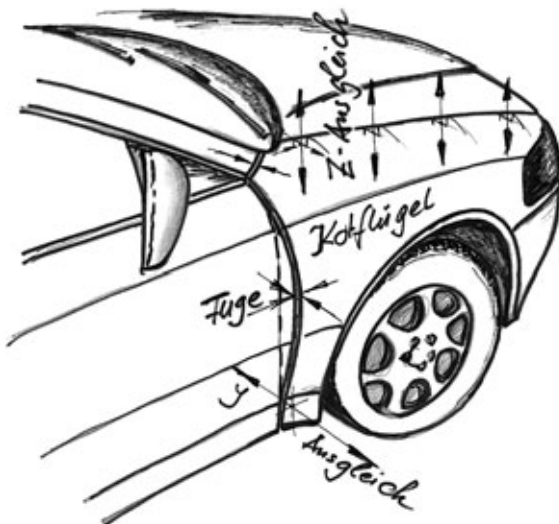
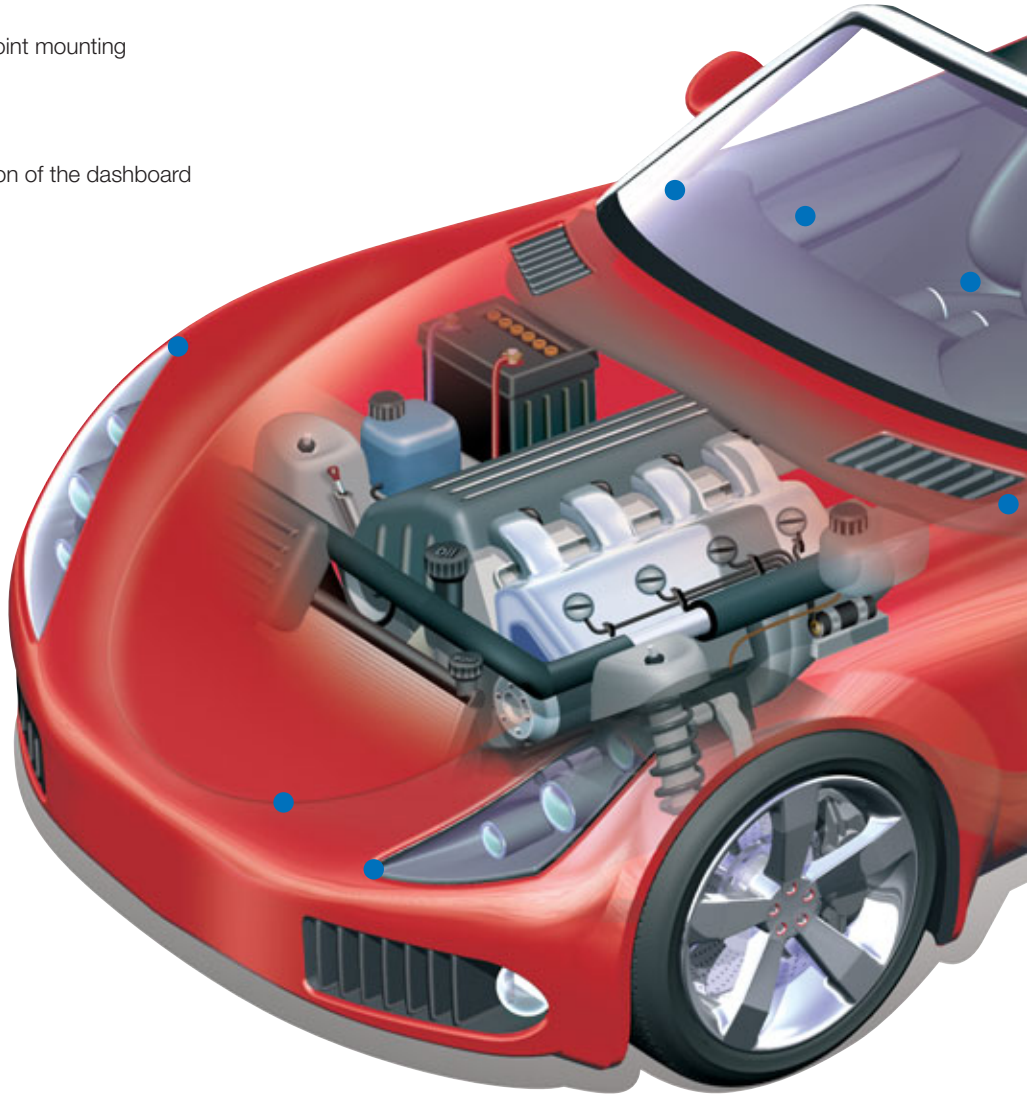

1 Element (A) = spannungsfreie Sitzschienen-Montage
 2 Elemente (A, C) = Ausrichten der Sitze zueinander

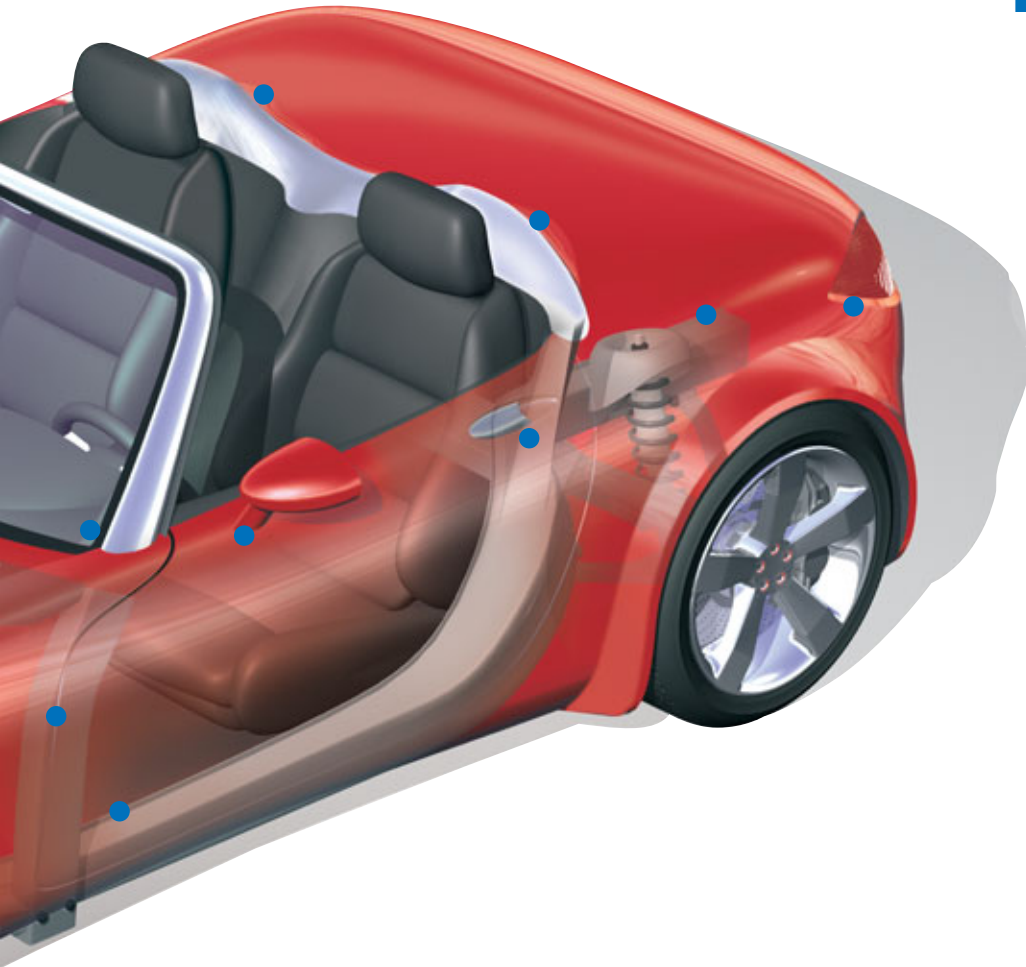

- Stress-free installation of the glass sliding roof
- Tolerance compensation for tail-light installation
- Precise installation of the gear changing unit
- Tolerance compensation of the door handle
- Fastening of roof rails
- Stress-free installation of large plastic covers

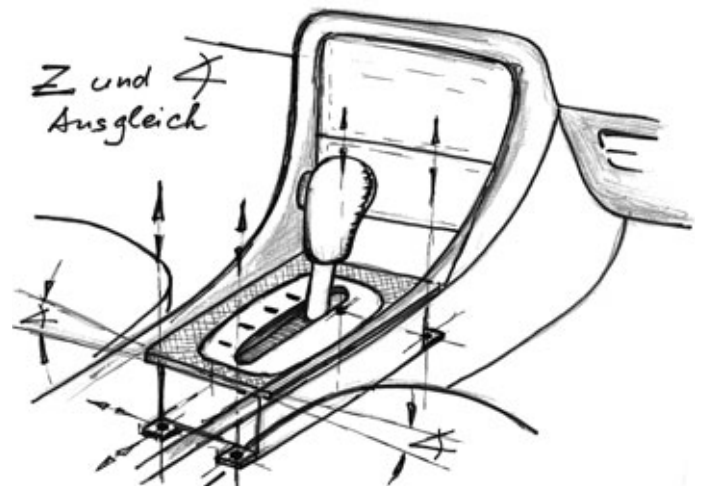
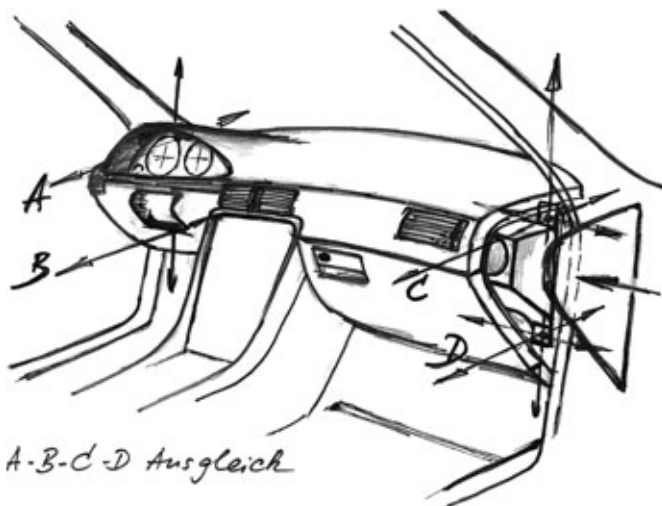

Special solutions for the automotive industry

Rear light fastening
FLEXITOL® manual tolerance compensation



Component parts for rear light fastening

The spring unit ① serves to ensure that the rear light is always tightened to the body with a defined tensile load. A further point of contact of rear light and body is provided with an adjustable spacer ②.

Furthermore, the surface offset between rear light and body side wall is achieved by means of an adjustable guide ③. During installation, the rear light is screw fastened to the body from within the trunk using the spring-loaded unit.

After installation, an ideal gap width can be adjusted for the rear light. The spring compensates the alignment movement.

To be able to remove the rear light for servicing, the spring unit can be unscrewed and the original position is maintained.



Schematic representation of rear light fastening

Manual

Fastening of roof rails **FLEXITOL® manual and automatic** **tolerance compensation**



Manual tolerance compensation

When roof rails are assembled no high forces may be transmitted through into the thin sheet metal of the roof panel. The tolerance compensation system specially developed by Böllhoff transfers these high forces into the supporting sheet layers below.

Tolerances within the cantrail do not affect the gap width between roof rail and roof panel. There are a variety of systems available which can be pre-installed on the roof rail or into the body.



Automatic tolerance compensation

Böllhoff International with companies in:

Argentina
Austria
Brazil
Canada
China
Czech Republic
France
Germany
Hungary
India
Italy
Japan
Korea
Mexico
Poland
Romania
Russia
Slovakia
Spain
Switzerland
Turkey
United Kingdom
USA

Apart from these 23 countries, Böllhoff supports its international customers in other important industrial markets in close partnership with agents and dealers.



Made of paper certified with the Ecolab of the European Community (Reg No. FR/11/003).
Printed by FSC®-certified company GFA-COC-001790.

Subject to technical change.
Reprinting, even in extract form, only permitted with express consent.
Observe protective note according to DIN 34.

Böllhoff Group
Please find your local contact on www.boellhoff.com
or contact us under fasteningtechnology@boellhoff.com

