

CombiTac programme: the winning combination

Simultaneous
energy connection





CombiTac programme: a tailor-made solution...

As an expert in industrial connections for over 50 years, Stäubli is constantly developing its expertise for all sectors of industry.

CombiTac solutions allow for the simultaneous connection of the following circuits:

- Compressed air
- Industrial vacuum
- Cooling fluids
- Electricity (power and signal)

Centralised connection for optimised productivity and safety

Time savings

Connects the energy circuits for your process and on-site maintenance equipment in a single movement.

Optimised safety

- **A single coupling position** to eliminate any risk of reversing the circuits
- **Flush-face connectors for fluid circuits:** this technology helps to maintain leak-tightness during connection and disconnection operations. Ideally suited to applications combining fluid and electrical circuits.
- **Electrical contacts with MC Multilam technology** for a permanent electrical contact.

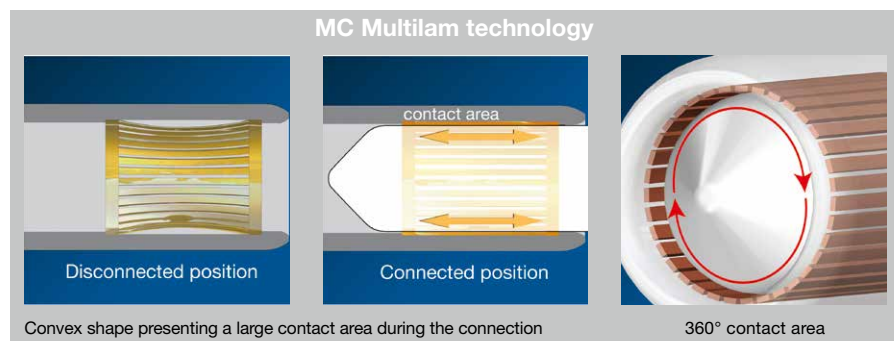

Reliability

- Tried and tested reliability for 1 to 5 connection cycles per day
- Design protects components from impacts and external stresses



Contents

Modules equipped with:

- > Cooling fluid couplings SCT..... 4 & 5
- > Compressed air and industrial vacuum couplings (UCT) 6 & 7
- > Compressed air and industrial vacuum couplings (RCT) 8 & 9
- > Electrical contacts..... 10 & 11
- > Coaxial and thermocouple contacts 12
- Electrical data**..... 14 & 15
- Siting and space requirements:**
- > Housing and bases 16 to 18
- > Rackable solutions..... 19

...for simple, accurate connections

Because each application deserves a perfectly adapted response, you formulate your own CombiTac solution from a complete range of independent modules; choose and assemble modules to suit your own requirements.

A wide range of fully equipped modules

Modules for pneumatic and industrial vacuum circuits

- 2 connection models
- 3 bore diameters
- Full flow or simple shut-off



Modules for cooling circuits

- 2 bore diameters
- Flush-face pollution control technology



Modules for electrical circuits

- Simple contacts (7 diameters)
- Specific contacts: thermocouples, coaxial, fibre-optic and data bus



2 module assembly configurations

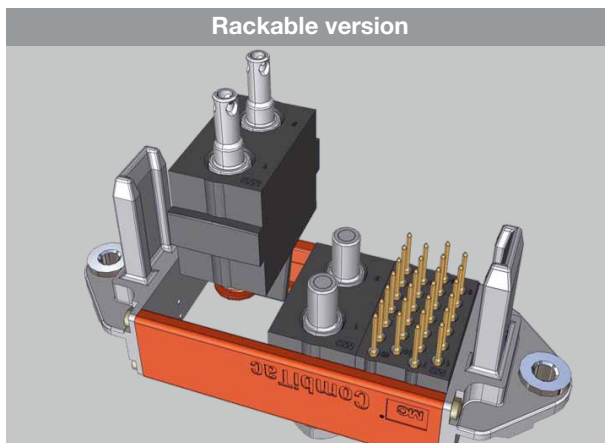

Rackable solution for automatic connections

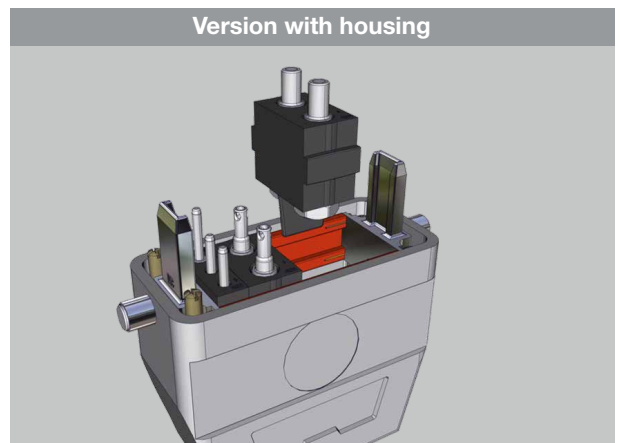



Solution with housing and base for manual connections

Part numbers modules fitted with SCT





non-spill design - double shut-off

SCT 03 for G 1/8 female connection

Cooling	Number of SCT per module	Description SCT 03			Part numbers modules fitted with SCT 03 
		Working pressure bar	Connection	SCT type	
	2	15	G 1/8 female	socket	SCT 103 02 1100
				plug	SCT 103 02 7100
	4	15	G 1/8 female	socket	SCT 103 04 1100
				plug	SCT 103 04 7100

SCT 05 for G 1/4 female connection

Cooling	Number of SCT per module	Description SCT 05			Part numbers modules fitted with SCT 05 
		Working pressure bar	Connection	SCT type	
	2	15	G 1/4 female	socket	SCT 105 02 1101
				plug	SCT 105 02 7101

The SCT 05 are dedicated to rackable versions.

Stainless steel versions: add **/IC** at the end of the part-numbers.

Example: SCT 103 02 1100/IC

Types of seals:

- Nitrile (NBR) as standard.
- Ethylene-Propylene: add **/JE** at the end of the part-numbers.
- Fluorocarbon: add **/JV** at the end of the part-numbers.

Example: SCT 105 02 1101/JE

FDA versions available in stainless steel SCT with JE seals: add **/IC/JE/FDA** at the end of the part-numbers.

Example: SCT 103 02 1100/IC/JE/FDA

Lubricants and seals used in compliance with the "FDA requirement":

- G20 lubricant conforms to NSF-H1 (no. 056372).
- EPDM elastomer seal according to inertia criteria of the regulation American FDA-CFR21, paragraph 177-2600 (IANESCO report no. 2355).



Technical characteristics

Nominal bore (mm)	03 - 05
Max. working pressure* (bar)	15
Mini. working pressure (torr)	10
Working temperatures (°C)	- 15 to + 90
Shut-off	double
Seals	NBR

These characteristics are applicable to the equipped modules only. Please ensure the temperature and pressure ratings are not exceeded on any tubing connected to the modules.

Pneumatic flow rate / pressure drop

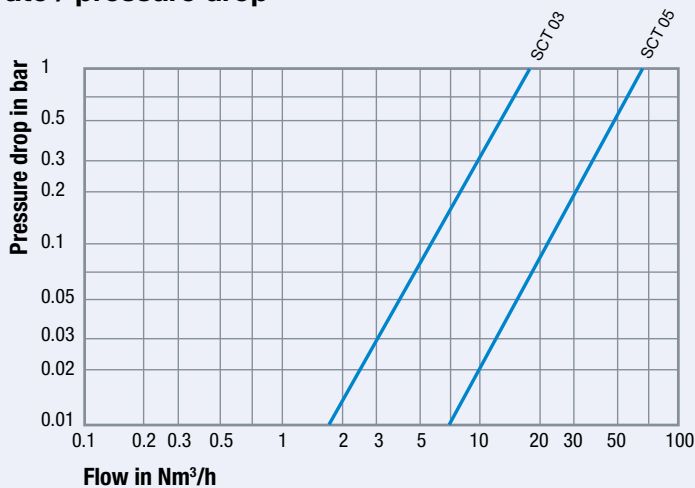

Test condition

- Direction of flow: socket → plug
- Supply pressure: 6 bar

Hydraulic flow rate / pressure drop

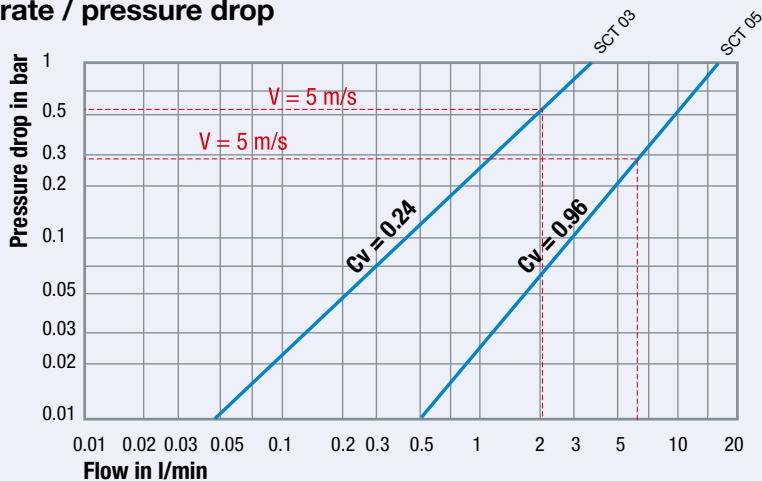

Test condition

- Direction of flow: plug → socket
- Hydraulic oil INVAROL FJ13 (H515 at 40°C)
- Density: 833 kg/m³
- Viscosity: 13.4 cSt

Part numbers modules fitted with UCT



full flow

UCT 04

Compressed air	Number of UCT per module	Description UCT 04			UCT type	Part numbers modules fitted with UCT 04 ←
		Working pressure bar	Connection* tube outside Ø			
			mm	"		
	2	15	6		socket	UCT 104 02 1904
					plug	UCT 104 02 6904
		15		1/4	socket	UCT 104 02 1933
					plug	UCT 104 02 6933
	4	15	6		socket	UCT 104 04 1904
					plug	UCT 104 04 6904
		15		1/4	socket	UCT 104 04 1933
					plug	UCT 104 04 6933

*Self locking connection on to calibrated polyamide or polyurethane tubing.

UCT 06

Compressed air	Number of UCT per module	Description UCT 06			UCT type	Part numbers modules fitted with UCT 06 ←
		Working pressure bar	Connection* tube outside Ø			
			mm	"		
	1	15	8	(5/16")	socket	UCT 106 01 1906
					plug	UCT 106 01 6906
	2	15	8	(5/16")	socket	UCT 106 02 1906
					plug	UCT 106 02 6906
	4	15	8	(5/16")	socket	UCT 106 04 1906
					plug	UCT 106 04 6906

*Self locking connection on to calibrated polyamide or polyurethane tubing.

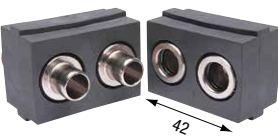

UCT 08

Compressed air	Number of UCT per module	Description UCT 08			UCT type	Part numbers modules fitted with UCT 08 ←
		Working pressure bar	Connection* tube outside Ø			
			mm	"		
	1	15	10		socket	UCT 108 01 1908
					plug	UCT 108 01 6908
		15		3/8	socket	UCT 108 01 1935
					plug	UCT 108 01 6935
	2	15	10		socket	UCT 108 02 1908
					plug	UCT 108 02 6908
		15		3/8	socket	UCT 108 02 1935
					plug	UCT 108 02 6935

*Self locking connection on to calibrated polyamide or polyurethane tubing.

Technical characteristics

Nominal bore (mm)	04 - 06 - 08
Max. working pressure (bar)	15
Mini. working pressure (torr)	10
Working temperatures (°C)	- 15 to + 80
Shut-off	full flow
Seals	NBR

These characteristics are applicable to the equipped modules only. Please ensure the temperature and pressure ratings are not exceeded on any tubing connected to the modules.

Pneumatic flow rate / pressure drop

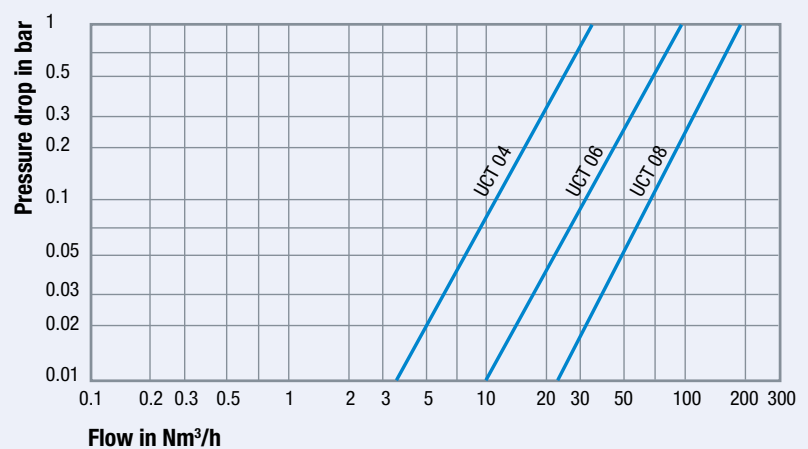

- Test condition**
- Direction of flow: plug → socket
 - Supply pressure: 6 bar

Part numbers modules fitted with RCT



full flow



Single shut-off

RCT 03 Full flow or single shut-off

Compressed air	Number of RCT per module	Description RCT 03				Part numbers modules fitted with	
		Working pressure bar	Connection* tube outside Ø		RCT type	RCT 03	RCT 03
			mm	"			
	2	15	4	(5/32")	socket	RCT 103 02 1902/OS	RCT 103 02 1902
					plug	RCT 103 02 6902	
		15	6		socket PLV	RCT 103 02 1904/OS	RCT 103 02 1904
					plug	RCT 103 02 6904	
		15	1/4		socket	RCT 103 02 1933/OS	RCT 103 02 1933
					plug	RCT 103 02 6933	
	4	15	4	(5/32")	socket PLV	RCT 103 04 1902/OS	RCT 103 04 1902
					plug	RCT 103 04 6902	
		15	6		socket	RCT 103 04 1904/OS	RCT 103 04 1904
					plug	RCT 103 04 6904	
		15	1/4		socket	RCT 103 04 1933/OS	RCT 103 04 1933
					plug	RCT 103 04 6933	

*Self locking connection on to calibrated polyamide or polyurethane tubing.

RCT 06 Single shut-off

Compressed air	Number of RCT per module	Description RCT 06				Part numbers modules fitted with	
		Working pressure bar	Connection* tube outside Ø		RCT type	RCT 06	RCT 06
			mm	"			
	1	15	8	(5/16")	socket PLV		RCT 106 01 1906
					plug	RCT 106 01 6906	
	2	15	8	(5/16")	socket PLV		RCT 106 02 1906
					plug	RCT 106 02 6906	

*Self locking connection on to calibrated polyamide or polyurethane tubing.



Modules available with PLV option for hose connection with a nut. Add **/PLV** at the end of the module part-numbers. E.g. RCT 103 02 1904/OS/PLV.

PLV option adaptable for tubes:	
Inside Ø (mm)	Outside Ø (mm)
2	4
4	6
6	8

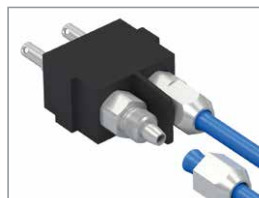



Technical characteristics

Nominal bore (mm)	03-06
Max. working pressure (bar)	15
Min. working pressure (torr)	10
Working temperatures (°C)	- 15 to + 80
Shut-off	full flow or single shut-off
Seals	NBR

These characteristics are applicable to the equipped modules only. Please ensure the temperature and pressure ratings are not exceeded on any tubing connected to the modules.

Pneumatic flow rate / pressure drop

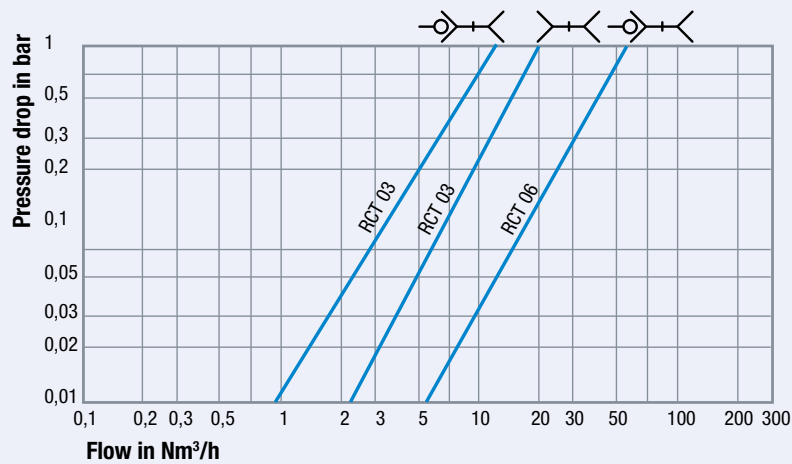

Test condition



- Direction of flow: socket → plug
- Supply pressure: 6 bar

Modules equipped with electrical contacts

Ø 0.6 mm

Electricity	Number of contacts	Rated current A	Cable cross section mm ²	Rated voltage V	Type of contact	Equipped module part-numbers with gold plated ●
	20	1.4 - 2	0.14 - 0.25	50 CAT III	socket	ECT 106 20 1001/D
					pin	ECT 106 20 6001/D

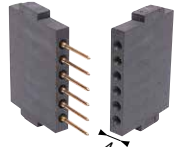

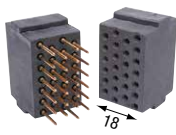
Ø 1 mm

Electricity	Number of contacts	Rated current A	Cable cross section mm ²	Rated voltage V	Type of contact	Equipped module part-numbers with gold plated ●
	6	2 - 5	0.25 - 0.75	150 CAT III	socket	ECT 110 06 1001/D
					pin	ECT 110 06 6001/D
	15	2 - 5	0.25 - 0.75	150 CAT III	socket	ECT 110 15 1001/D
					pin	ECT 110 15 6001/D
	26	2 - 5	0.25 - 0.75	150 CAT III	socket	ECT 110 26 1001/D
					pin	ECT 110 26 6001/D

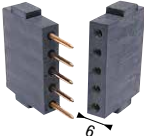
Ø 1.5 mm

Electricity	Number of contacts	Rated current A	Cable cross section mm ²	Rated voltage V	Type of contact	Equipped module part-numbers with gold plated ●
	5	5 - 10	0.5 - 1.5	250 CAT III	socket	ECT 115 05 1002/D
					pin	ECT 115 05 6002/D

Ø 3 mm

Electricity	Number of contacts	Rated current A	Cable cross section mm ²	Rated voltage V	Type of contact	Equipped module part-numbers with gold plated ●
	3	22 - 35	2.5 - 4	400 CAT III	socket	ECT 130 03 1004/D
					pin	ECT 130 03 6004/D
	2 active contacts 1 earth contact	22 - 35	2.5 - 4	400 CAT III	socket	ECT 130 03 1004/GND/D
					pin	ECT 130 03 6004/GND/D

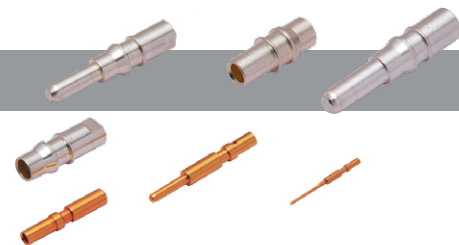

Ø 6 mm

Electricity	Number of contacts	Rated current A	Cable cross section mm ²	Rated voltage V	Type of contact	Equipped module part-numbers with silver plated ○
	2	40	6	500 CAT III	socket	ECT 160 02 1006
					pin	ECT 160 02 6006
		55	10		socket	ECT 160 02 1010
					pin	ECT 160 02 6010
	1	100	16	-	earth socket	ECT 160 01 1016/GND
					earth pin	ECT 160 01 6016/GND

Ø 8 mm

Electricity	Number of contacts	Rated current A	Cable cross section mm ²	Rated voltage V	Type of contact	Equipped module part-numbers with silver plated ○	Equipped module part-numbers with gold plated ●
	2	55	10	300 CAT III	socket	ECT 180 02 1010	ECT 180 02 1010/D
					pin	ECT 180 02 6010	ECT 180 02 6010/D
		75	16		socket	ECT 180 02 1016	ECT 180 02 1016/D
					pin	ECT 180 02 6016	ECT 180 02 6016/D
		100	25		socket	ECT 180 02 1025	ECT 180 02 1025/D
			pin	ECT 180 02 6025	ECT 180 02 6025/D		
	1	125	25	-	earth socket	ECT 180 01 1025/GND	
					earth pin	ECT 180 01 6025/GND	

Ø 12 mm

High current	Number of contacts	Rated current A	Cable cross section mm ²	Rated voltage V	Type of contact	Equipped module part-numbers with silver plated ○
	1	200	50	800 CAT III	socket	ECT 192 01 1050
					pin	ECT 192 01 6050
		245	70		socket	ECT 192 01 1070
					pin	ECT 192 01 6070
		300	95		socket	ECT 192 01 1095
			pin	ECT 192 01 6095		
	1	200	50	-	earth socket	ECT 180 01 1050/GND
					earth pin	ECT 180 01 6050/GND

All electrical connections on the CombiTac modules on pages 10 and 11 to be crimped.

All female electric inserts on pages 10 and 11 are IP2X. The male electric inserts Ø 12 mm are also IP2X.

Module part-numbers equipped with contacts for Ø 2 mm thermocouples

Thermocouple	Number of contacts per module	Cable cross section mm ²	Type of contact		Equipped module part-numbers
	2 thermocouple pressure contacts; 1 earth contact	0.14 – 0.5	type E Chromel + Constantan	socket	TCT 120 03 1001/E
				pin	TCT 120 03 6001/E
			type J Iron + Constantan	socket	TCT 120 03 1001/J
				pin	TCT 120 03 6001/J
			type K Chromel + Alumel	socket	TCT 120 03 1001/K
				pin	TCT 120 03 6001/K
			type N Nicrosil + Nisil	socket	TCT 120 03 1001/N
				pin	TCT 120 03 6001/N
			type T Copper + Constantan	socket	TCT 120 03 1001/T
				pin	TCT 120 03 6001/T



Module part-numbers equipped with RG 59 coaxial contacts *according to CECC 22 120*

Coaxial contact	Number of contacts per module	Voltage standing wave ratio	Rated voltage earth shielding	Cable section mm ²	Impedance ohm	Surface treatment	Type of contact	Equipped module part-numbers
	2	VSWR 75 Ohm: 1.5 @ < 500 MHz	1000 V, Cat 2 according to IEC 61010	6.5	75	Core: CuZn, Au Shielding: CUZn, Ni	RG 59 socket	XCT 180 02 1059
							RG 59 pin	XCT 180 02 6059

Module part-numbers equipped with fibre-optics

Plastic optical fibre	Number of contacts per module	Ø of core µm	Ø of first jacket µm	Length of bandwidth	Digital opening	Insertion loss	Type of contact	Equipped module part-numbers
	3 pressure contacts	980/1000	2200	1 MHz-km at 650 nm	0.47	< 3 dB at 650 nm	POF LWL socket	OCT 115 03 1000/POF
							POF LWL pin	OCT 115 03 6000/POF

Module part-numbers equipped with data bus contacts

Ethernet	Number of contacts per module	Data transmission	Output	Type of contact	Equipped module part-numbers
	2 connections of 8 contacts	CAT 5 Ethernet IEEE 802.3 Profi-bus Profi-net Interbus CAN-BUS	8 AU cables 0.14 mm ² - 0.75 mm ² 1.6 mOhm to be crimped	CT NET socket	NCT 110 16 1001
				CT NET pin	NCT 110 16 6001
	2 connections of 8 contacts	CAT 5 Ethernet IEEE 802.3	8-pole RJ45 connector	RJ45 socket	NCT 191 02 1045
				RJ45 pin	NCT 191 02 6045

All electrical connections on the CombiTac modules on pages 12 and 13 are to be crimped, except for the RJ45 connectors.

The values given correspond with the operating conditions below:

- rated voltage: phase / earth AC DC, pollution degree 3 and overvoltage category III, conformity with IEC 60664-1 (additional data on page 15)
- Rated current maximum cable cross section and 20°C working temperature (for other temperatures and cable cross sections, refer to the derating diagrams on page 14)

Recommendations:

- Connection and disconnection off-load.
 - In accordance with the IEC/TR 61201 standard, the extra low voltages are 33 Vac and 70 Vdc.
- For any application with higher voltages, extra protection measures must be taken (protective shields, circuit breakers, etc.).

For all other operating conditions, contact your Stäubli specialist.

For solutions with modules fitted with electrical contacts next to modules fitted with cooling couplings, it is imperative to regularly check the condition and functioning of products and to replace them if necessary.

Electrical data

Derating diagrams

Determination of the rated current according to temperature. The derating diagram shows the continuous current (not intermittent) that

flows through all the contact elements of a connector at one time, whereby the max. temperature limit is not exceeded. (Calibration and test method according to IEC 60512-5-2).

The derating diagram values are valid for the connection (see standard EN 60204). The permissible current load of the cables can be seen in DIN VDE 0298-4 and DIN EN 60204-1, IEC 60204-1.

Electrical contacts with cable cross sections from 0.25 to 1.5 mm²

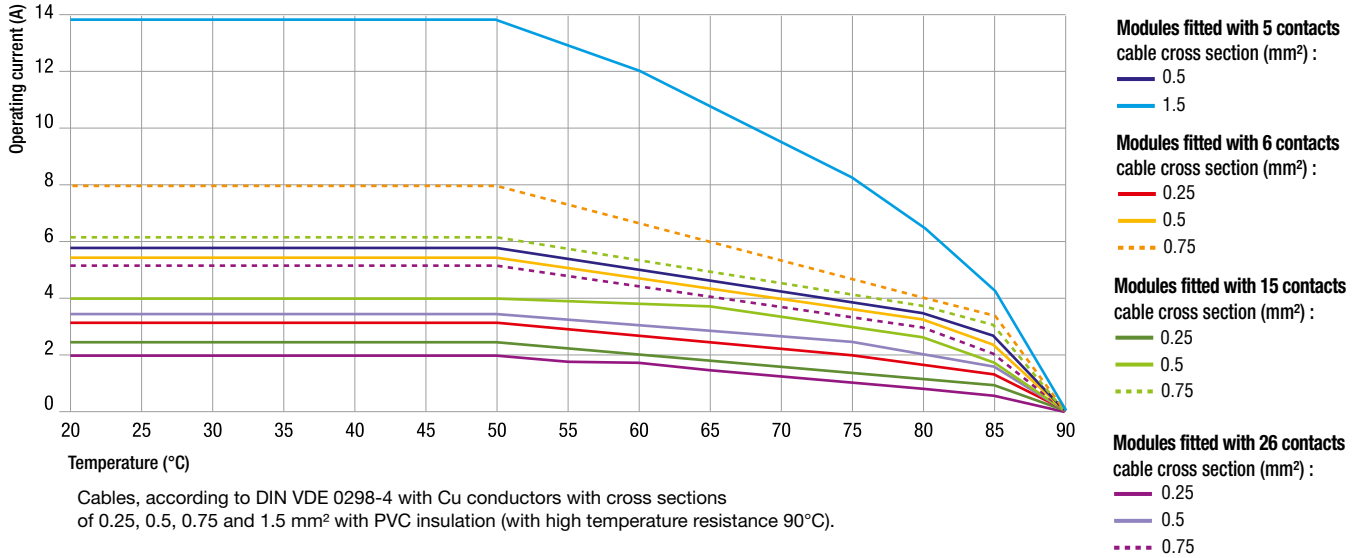

Electrical contacts with cable cross sections from 2.5 to 25 mm²

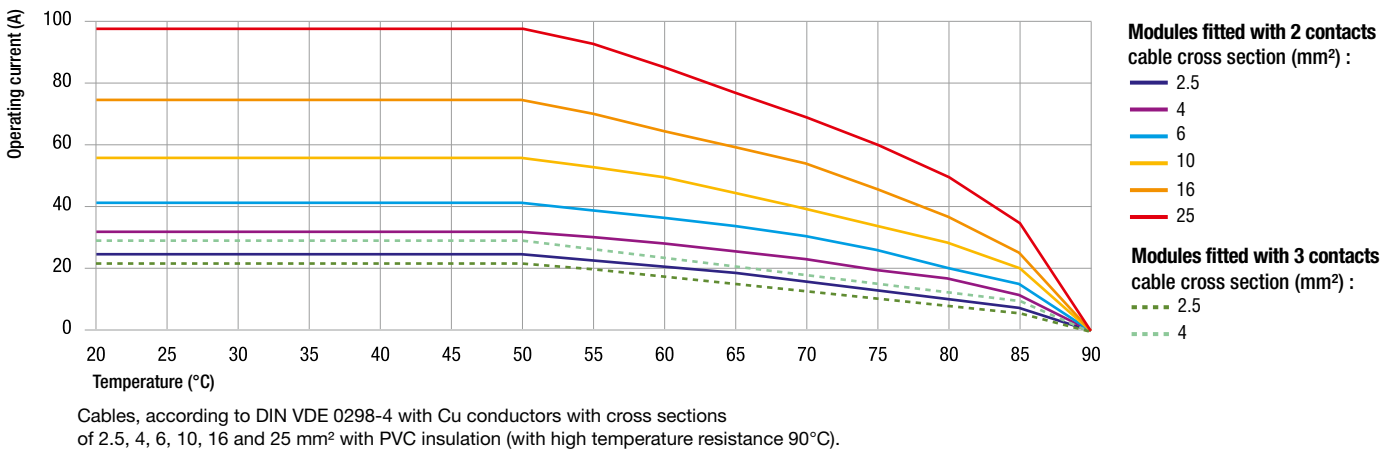

Electrical contacts with cable cross sections from 50 to 95 mm²

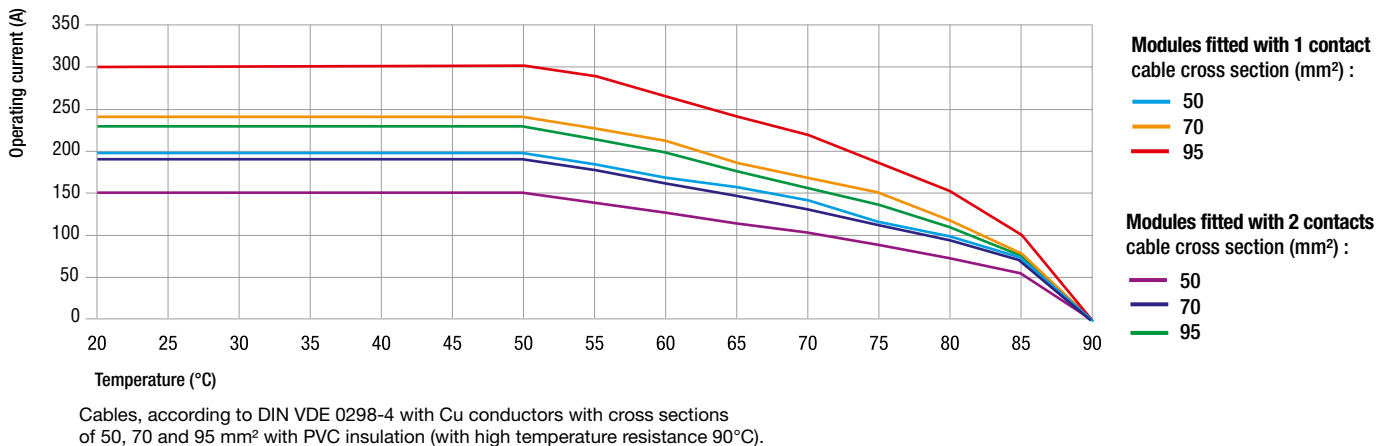

Rated current: the continuous current which can flow through every contact simultaneously without the temperature exceeding the allowed upper limit. The quoted current values were determined in a 4 hour temperature test according to UL 1977 with all contacts connected in series (-15° to 90°C).

Rated voltage: this is derived from the AC or DC line-to-earth (ground) voltage according to IEC 60664-1. In service, the rated voltage is dependent on whether the supply is:

- three-phase, four-wire with earthed (grounded) neutral or
- three-phase, three-wire unearthed (not grounded) or
- single-phase, two wire AC or DC.

Overvoltage categories CAT III: Equipment of overvoltage category III is equipment in fixed installations and for cases where the reliability and the availability of the equipment is subject to special requirements.

Examples of such equipment are switches in the fixed installation and equipment for industrial use with permanent connection to the fixed installation.

Pollution degree 3: (CEI 60664-1) Presence of conductive pollution or of dry non-conductive pollution which becomes conductive due to condensation which is to be expected.



Crimping tools

Designation	Section of conductor (mm ²)	Part-numbers
Crimping pliers	from 0.14 to 4	18.3800
Adjustable crimp die	0.14 - 4	18.3801
Crimp anvil	0.25 - 0.75	18.3804
Crimp anvil	0.5 - 1.5	18.3805
Crimp anvil	2.5 - 4	18.3806
Crimping pliers	from 6 to 25	18.3700
Crimp anvil	6	18.3701
Crimp anvil	10	18.3702
Crimp anvil	16	18.3703
Crimp anvil	25	18.3704
Crimping pliers	from 50 to 95	18.3710
Crimp anvil	50	18.3713
Crimp anvil	70	18.3711
Crimp anvil	95	18.3714
Pliers for coaxial contacts	–	33.3010
Wire stripper	–	33.3011
Fibre-optic pliers	–	33.3020
Polishing ring	–	33.3023

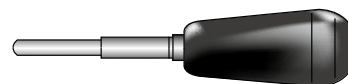

Socket and pin fitting and removal tools

Designation	Nom. Ø pin/socket (mm)	Part-numbers
Socket and pin fitting tools	0.6	33.3003
	1 and for thermocouples	33.3001
	1.5	18.3003
	3	18.3010
	6 and for fibre-optics	18.3013
	6 for coaxial contacts	18.3015
	8	18.3016
Socket removal tools	0.6	33.3002
	1	18.3001
	1.5 and for thermocouples	18.3004
	3	18.3011
	6 et 8	18.3017
	6 for fibre-optics	33.3022
	6 for coaxial contacts	18.3015
Pin removal tools	0.6	33.3002
	1	18.3002
	1.5 and for thermocouples	18.3005
	3	18.3012
	6 and for fibre-optics	18.3018
	8 and for coaxial contacts	18.3022

Delivered with assembly instruction sheet.

Housings

A solution for every configuration:

- 6 housing and base sizes
- straight or side outlet
- bases in high version
- mobile base for extension: housing equipped with locking system.

Options:

- according to your configuration, the bases can be fitted with protective covers against shocks and external pollution.
- a protective shield against electric shocks can be added to the mobile housing (sizes 2 to 6) or the fixed bases (sizes 2 to 5). Depending on the operating conditions and above certain voltages, it may be mandatory (refer to IEC/TR 61201 standard). Incompatible with cover.
- protective cap: for mounting on all surface mounting and pedestal mountings or coupler hood with pin end pieces. Protective cover material PA.

Construction:

- aluminium alloy
- base fitted with flat seal for proper sealing onto panel.

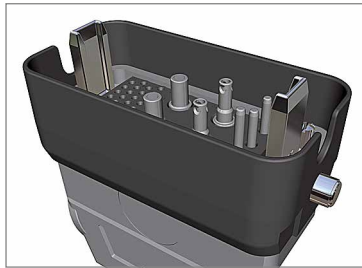

The CombiTac range is certified IP 65

(refer to IEC 60529) in connected position and with the use of an adequate cable box (not supplied): protection against dust and water projection (from a hose).

IP68 housing: please contact us.

Mobile base for extension

To create an extension, connect standard housing with a housing equipped with a locking system.

Dimensions of mobile housing (non-equipped)

Straight outlet mobile housing

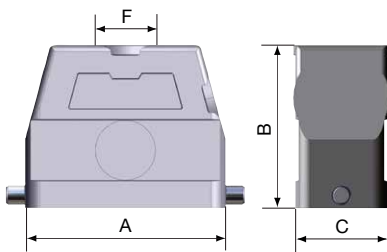

Side outlet mobile housing

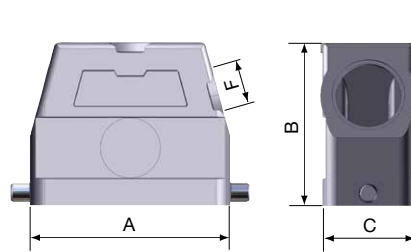

Mobile housing with locking system for extension

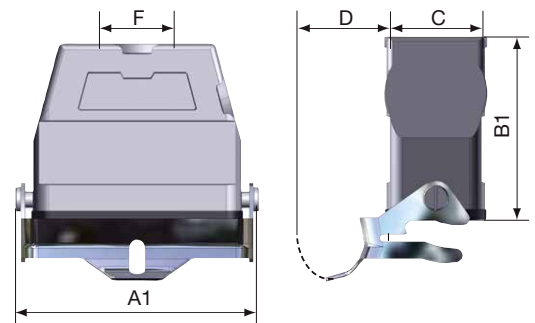

Sizes	A	B	C	A1	B1	D	1 outlet F
1	60	72	43	74	75	20	M 32x1.5
2	73	70	43	89	74	34	M 32x1.5
3	93.5	76	43	109.5	80	35	M 32x1.5
4	120	78	43	136	82	35	M 32x1.5
5	95	79	82.5	111	83	33	M 40x1.5
6	131	96	89	-	-	-	M 50x1.5

Dimensions of fixed bases (non-equipped)

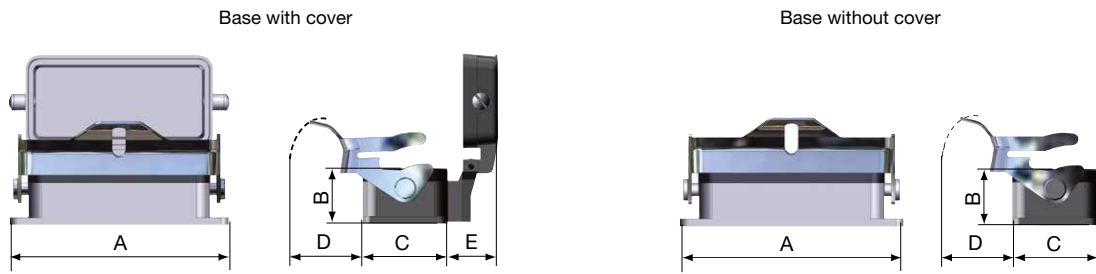

Sizes	A	B	C	D	E (with cover)
1	82	29	43	20	26.5
2	93	28.5	43.5	26	35
3	113	28.5	43.5	26	35
4	140	28.5	43.5	26	35
5	124	36	84	22	33
6	165	38.5	90	25	50

Dimensions of fixed bases* in high version, outlet 90° (non-equipped)

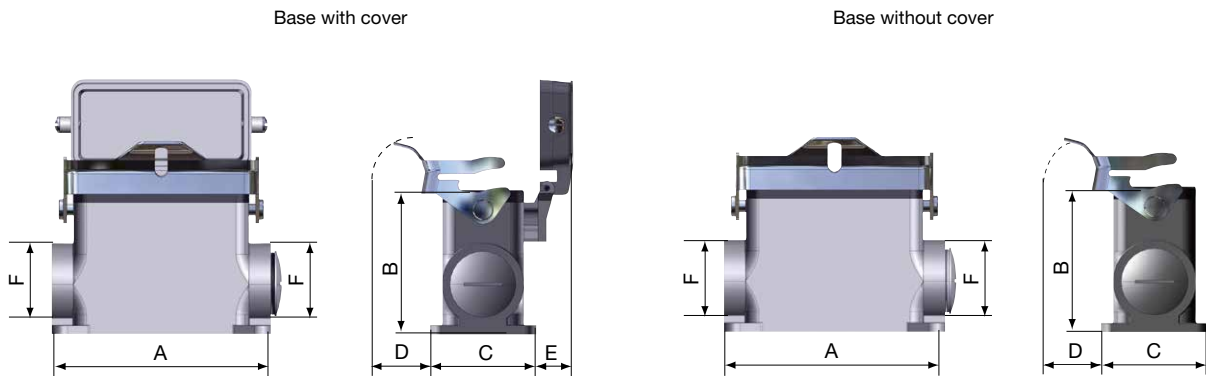

Sizes	A	B	C	D	E (with cover)	2 outlets F
1	82	74	54.5	13.5	20	M 32x1.5
2	94	74	57	30	20	M 32x1.5
3	117	77	57	29	22	M 32x1.5
4	144	78.5	57	30	20	M 32x1.5
5	126	78.5	84	33	22	M 32x1.5
6	140	98.5	120	37	10	M 40x1.5

* Base supplied with 1 cap.

Effective lengths and sizes

L (mm)	Size of housing
$L \leq 30$	1
$31 \leq L \leq 43$	2
$44 \leq L \leq 64$	3
$65 \leq L \leq 90$	4
$44 \leq L \leq 64$	5
$65 \leq L \leq 90$	6

Panel cutting of fixed bases

Sizes	A	B	C	D	E
1	52	36	70	32	M4
2	65	36	83	32	M4
3	86	36	103	32	M4
4	110	36	130	32	M4
5	82	71	110	65	M5
6	117	81	148	70	M6

Panel cutting of high bases

Sizes	C	D	E
1	70	45	M5
2	82	45	M5
3	105	45	M5
4	132	45	M5
5	112	67	M5
6	111	106	M6

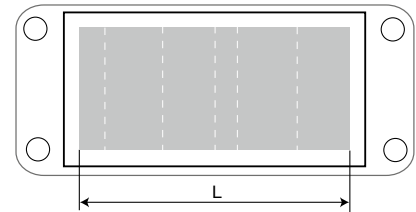

Sizes 1, 2, 3 and 4

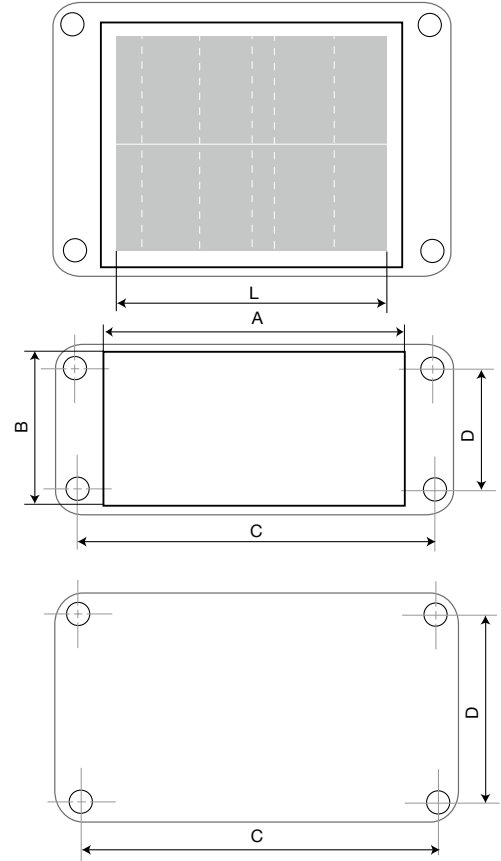

Sizes 5 and 6



Parking stations

Non equipped bases for parking	Part numbers parking bases					
	size 1	size 2	size 3	size 4	size 5	size 6
 with male end pieces	34.0340	34.0342	34.0344	34.0346	34.0348	34.0350
 with female end pieces	34.0341	34.0343	34.0345	34.0347	34.0349	34.0351

Encoding solutions

- standard configuration

- other possible encoding for asymmetric configurations

- there are additional encoding solutions for size 5 and 6 housings

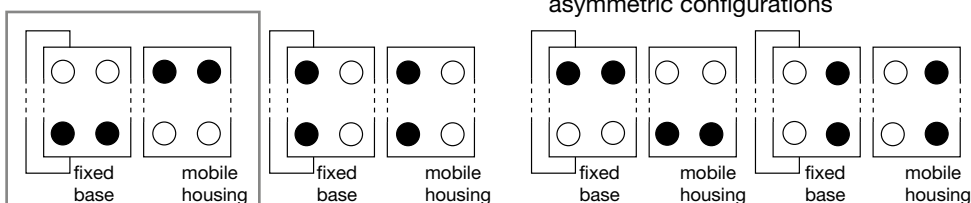

● high screw heads ○ low screw heads

Rackable solutions



Installation

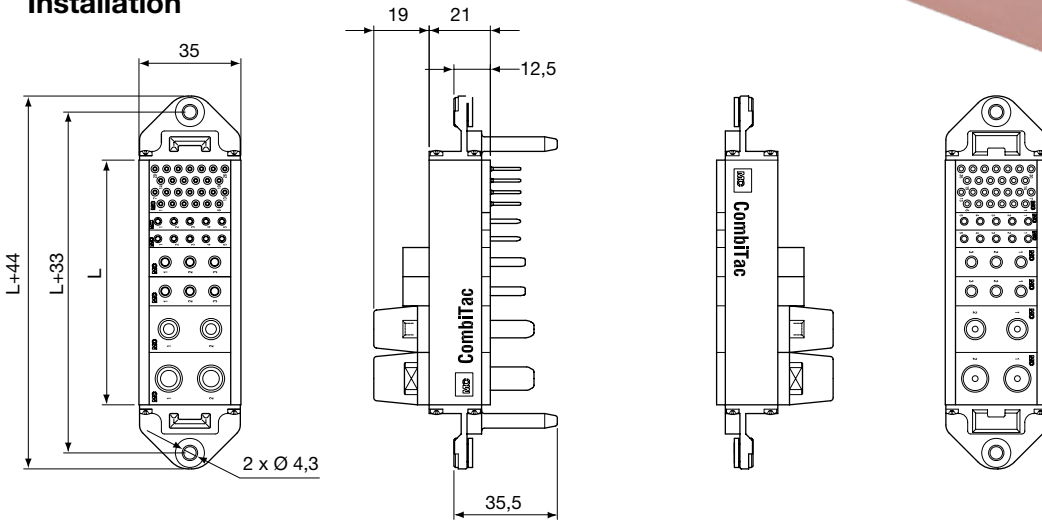

L = Sum of modules widths.
 Minimal length = 18 mm if necessary, possibility of completing with spacers.

Maximum permissible interface offset

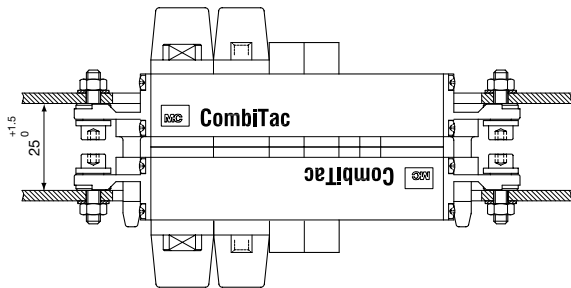

Adjustment of misalignment while connecting

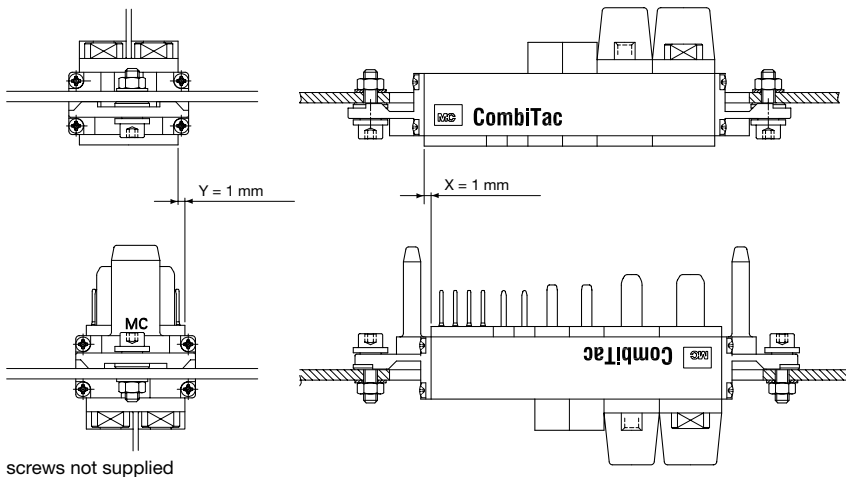

screws not supplied

Recommendation:

The rackable installation guiding columns are only intended to guide the CombiTac. They do not compensate for a poor configuration of the complete application. In that case it is necessary to ensure a preguiding of your installation.

For contact details: www.staubli.com/connectors/contacts

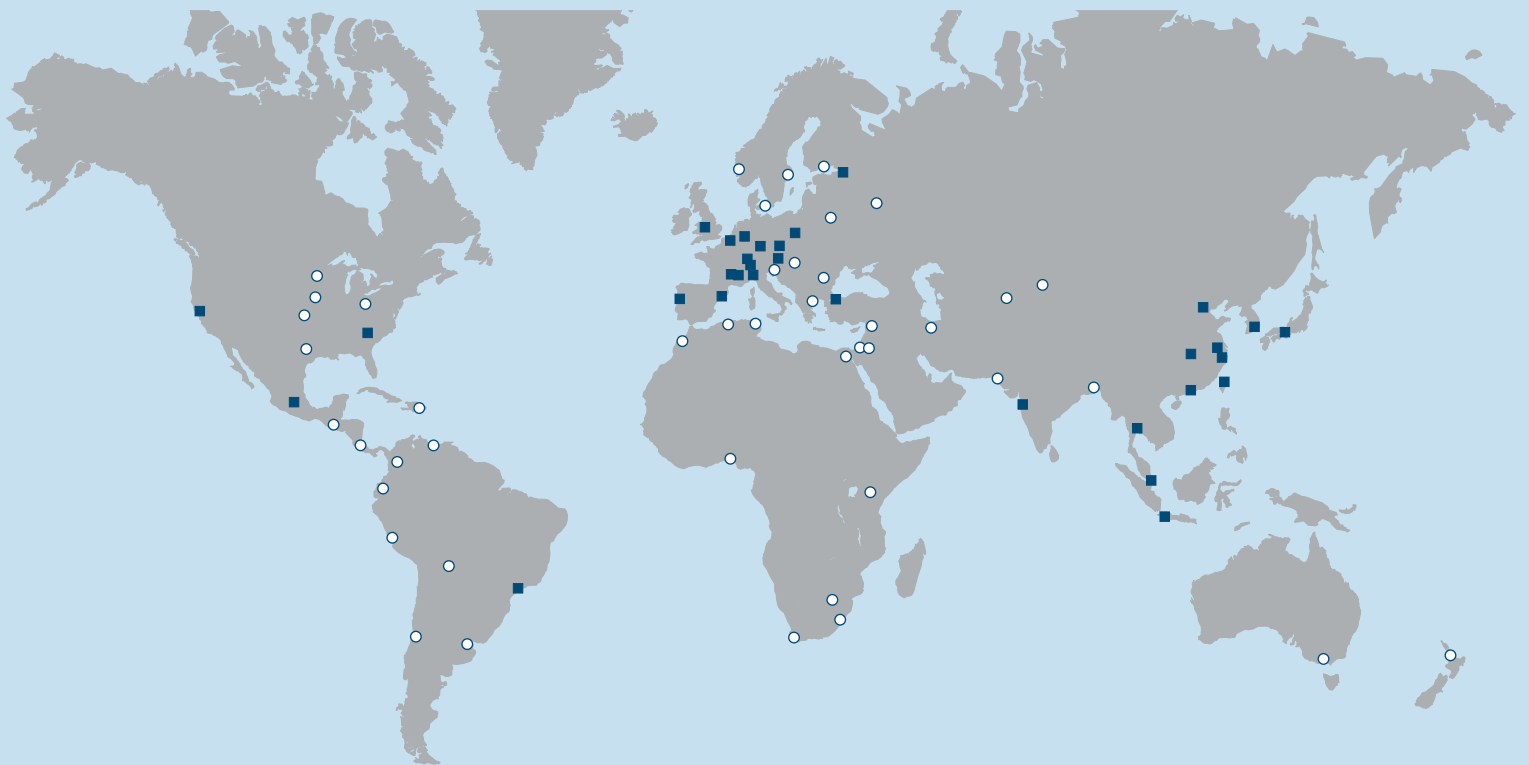

Global presence of the Stäubli Group

- Stäubli units
- Agents

International sales coordination

Stäubli Faverges - CS 30070 - F - 74210 Faverges - Tel.: +33 4 50 65 67 97 - Fax: +33 4 50 65 60 69 - E-mail: connectors.sales@staubli.com
www.staubli.com

Stäubli is a trademark of Stäubli International AG, registered in Switzerland and other countries. © Stäubli 05/09/2014. Printed on FSC paper.
We reserve the right to modify product specifications without prior notice. Photocredits: Stäubli / Estelle Perdu - Michel Boudier

RH1500303A

STÄUBLI